

This handout shows you how to present data using an illustration such as a figure or table. While the specific citation format for your illustrations will vary depending on your style and genre, most writers follow the same principles when introducing data.

Common Guidelines

“Skimmability”

When reading a research paper, readers will often skim the paper for relevant information. When writing your paper, ask yourself:

- Who are my audiences?
- What information do they want to find in my writing?
- Where is the first place they would look for this information?

You want to make your information to be as “skimmable” as possible, with concise, descriptive topic sentences and clear illustrations.

Illustration Identifiers and Titles

Illustrations usually have titles that include both an identifier (like “Figure 1”) and a brief description. To create a clear distinction between the title and surrounding text, you could leave more space between the illustration and your paragraphs than you leave between the illustration and its title.

Introducing and Discussing an Illustration

Illustrations usually appear at the earliest natural break (e.g., paragraph break or page break) after they have been introduced. Introduce the illustration with the identifier (like “See Table 1”). If there isn’t enough space below that paragraph, it’s okay to add the illustration on the next page. Another way to improve readability is to separate your illustration from your text with empty lines.

Addressing the Shortcomings of Data

Data serve as evidence for your arguments or findings, and that evidence will never be perfect. By presenting other interpretations of and identifying issues with your data, you open your work to others who wish to expand your research. Good places to start include asking yourself:

- Did the collection method for the data affect their accuracy?
- How recent are the data?
- Are there ways in which the data contradict my conclusions?

You can use these questions to examine your data objectively, making your research more accessible for expansion and establishing thoughtful nuance to your claims.

Figures

Figures are images like graphs or diagrams that allow a reader to visualize a concept that's difficult to put into words. Usually, writers introduce figures in the paragraph before they're shown. This paragraph elaborates on the data's meaning and relevance to your argument and draws conclusions. Be descriptive to guide your reader to the right conclusions about your data. Figures include a bold, descriptive, and capitalized title. Cite any content that is not your own, using the format specified for your class. The example below, Fig. 1, is formatted in IEEE style:

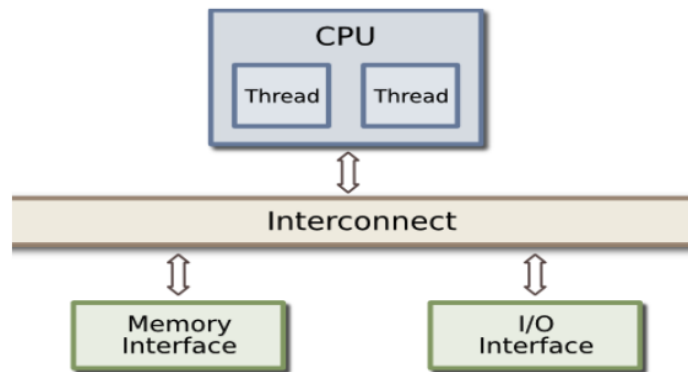

Figure 1. Block Diagram of a CPU [5]

Tables

Tables show data in an organized and readable way when a paragraph might be too tedious. They usually include column headings at the top and sometimes row headings on the left. Here in Table 1 is an example of how you include tables in text:

Table 1. Components for the Hat [2]-[5]

Part	Price	Availability
Hat	\$7.99	In stock
Sequins	\$16.99	Back ordered; Available 11/4
Figurine	\$4.99	In stock
Astroturf	\$2.99	In stock
Flowers	\$6.99	In stock

Notice the placement of the title in Table 1 as opposed to Figure 1. Table titles are typically placed above the visual, while Figure titles are placed below. Be careful not to overwhelm your reader with information in tables. Instead, use them to communicate relevant data effectively, and include only as much information as you think you need! For data tables, some professors and editors prefer the clean look of minimal gridlines.